



A compost dwelling worm found near Abobo, Ethiopia.

TIGER WORM TOILETS

Best Practice Guidelines for Refugee Camps

Angus McBride and Caroline Muturi, 2017

Photo Credits: Angus McBride/Oxfam



INTRODUCTION

Tiger Worm Toilets (sometimes known as vermifilter toilets) contain composting worms inside the toilet that digest faeces, reducing the accumulation rate and significantly extending the lifetime of the toilet. A worm colony can live inside the toilet indefinitely so long as the correct environmental conditions are maintained. In refugee camps which may exist for a long time this reduces the need to replace filled latrines and can therefore provide a more cost-effective solution in the long term.

The design has been developed and implemented in Jewi refugee camp in Gambella, Ethiopia, by Oxfam under the “Waste to Value” project funded by the Bill & Melinda Gates Foundation through UNHCR. This guide is intended to assist those implementing Tiger Worm Toilets in humanitarian settings, covering the community engagement undertaken as well as the physical design.

Refugee camps frequently last for decades, and providing suitable sanitation is essential to protect public health. Pit latrines are the most common sanitation solution because they are cheap and easy to build, but are problematic to build in areas with high water tables, and rocky or unstable soil, or to replace periodically in congested camps. Tiger Worm Toilets could provide a more cost-effective solution in these situations as they have shallow, small vaults and very low filling rates.

The design philosophy of the toilet has been to balance cost, ease of construction, and user acceptability. The aim is to have a design that can be easily rolled out to thousands of households in a camp setting either by a UNHCR Implementing Partner or a contractor, in a way comparable to a ‘typical’ household pit latrine roll-out. The design does not require specialists to implement, and uses local or readily available construction materials, and local construction methods/capabilities. The cost needs to be comparable to that of a household latrine, as this is ultimately a major factor in the choice of sanitation solution, and in the long run the Tiger Worm Toilet may be cheaper.

The table below gives a simple comparison between the Tiger Worm Toilet and a typical household pit latrine. These figures are based on experience from implementation in Gambella, Ethiopia.

Quick comparison of Tiger Worm Toilets and ‘typical’ pit latrines

	Lifespan	Long term strategy	Best for
Typical Pit Latrine	Two – three years	Rebuild & Replace	Rural, lots of space, good ground conditions
Tiger Worm Toilet	Five – ten years	Reduced faeces build up, empty & rehabilitate	Crowded areas, long term use

TIGER WORM TOILET FEATURES

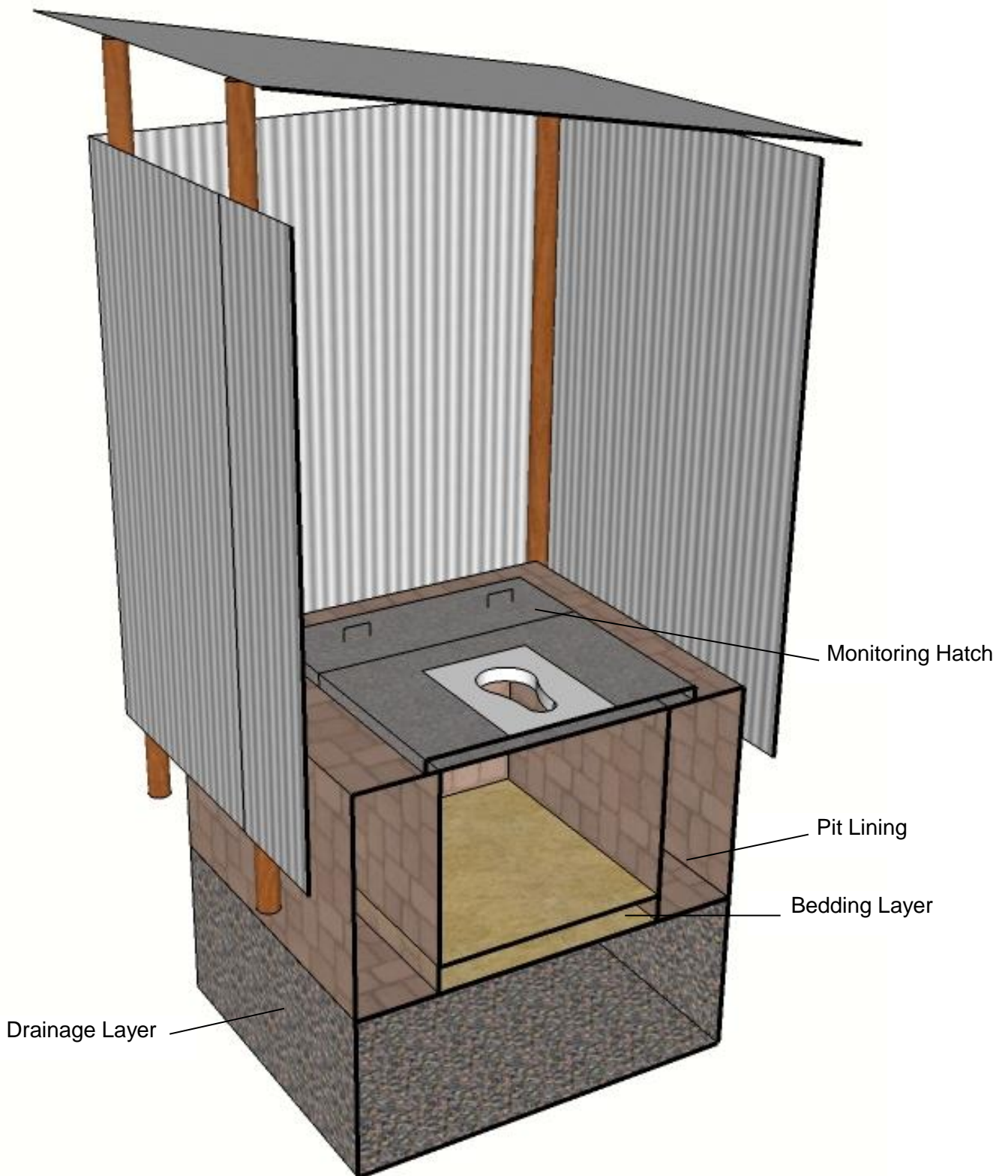



Cleaning materials

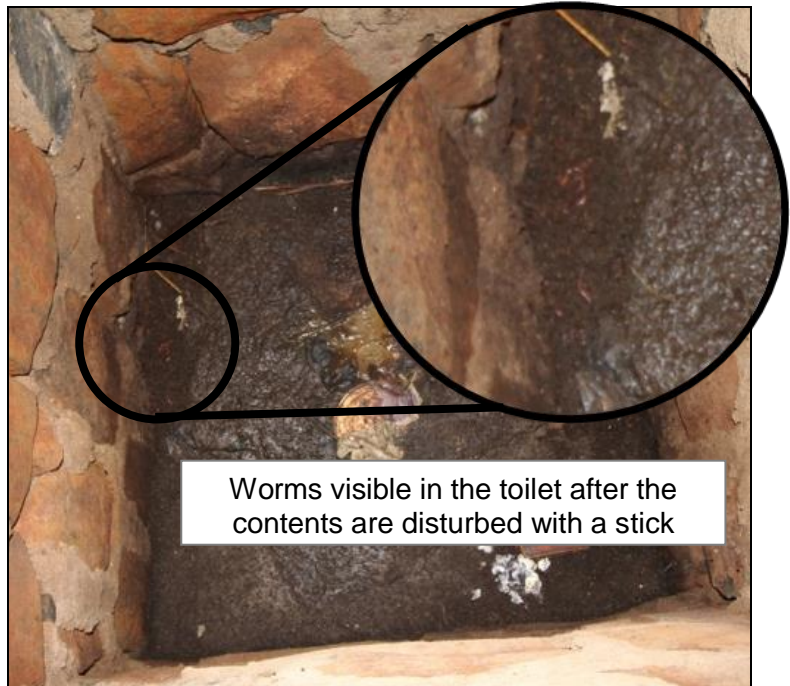

Worms visible in the toilet after the contents are disturbed with a stick

TECHNICAL SPECIFICATION

COMPOST DWELLING WORMS

Earthworms are common throughout the world. There are three main categories of earthworm:

1. Worms that burrow deep underground, occasionally visiting the surface to pull down plant material for food.
2. Worms living in the top 10 – 30cm of the ground that eat soil.
3. Compost-dwelling worms that do not burrow but live near the surface and eat decomposing organic material. These are the worms that are suitable for use inside the toilet.

There are several different species of compost-dwelling worm, and they are widely available around the world. The Tiger Worm (*Eisenia fetida* or its close relative *Eisenia andrei*), the African Nightcrawler (*Eudrilus eugeniae*) and the Indian Blue (*Perionyx excavatus*) are common types (Figure 1). Identifying specific species of worms is difficult and is not necessary. If it can be established that a worm is a compost-dwelling then it can be concluded that it will very likely be viable in a worm toilet.

Composting worms can eat their own bodyweight every day. They reduce the volume of material through conversion to carbon dioxide, water and ammonia, and because vermicast (worm faeces) is dense and dewateres easily.

Worms have various predators including birds, snakes, small mammals and invertebrates. Predators of particular relevance for tiger worm toilets are mice, rats and centipedes, and care should be taken that they are not able to access the tank.



Figure 1. Tiger Worms, the African Nightcrawler, and Indian Blue Worms

Bedding Layer

A bedding layer is necessary for the worms to live in whilst they are in the toilet. A good bedding material should retain moisture, retain its (porous, air-retaining) structure to prevent the toilet going anaerobic, and filter out the solids that are flushed. Possible bedding layers include woodchip, coconut fibre (coir) or compost (Figure 2). Lab tests have shown that woodchip may be the most effective bedding layer, although if it has too many fine particles then this could potentially cause clogging. Whichever bedding layer is chosen, it should be soaked overnight before installation in the toilet and be added at the same time as the worms to a depth of around ten centimetres.



Figure 2. Possible bedding layers: woodchip, coconut fibre (coir) or compost.

Sourcing and Growing Worms

In many places worms are grown commercially for use as fishing bait, for agricultural purposes converting organic waste, or for the processing of sewage sludge through vermifiltration. Alternatively, worms may be found living in the local environment, particularly in areas with high amounts of organic matter, for example in areas where cattle gather.

Sourcing worms in the quantities required for a large number of toilets may be difficult or expensive, but once an initial batch of worms have been sourced it is relatively easy to grow more. A wormery should have approximately one square metre for every five kilograms of worms. The wormery needs to be covered to protect from birds, be in a shady area to prevent overheating, and should have controlled drainage to ensure that it does not flood (Figure 3).

Inside the wormery a layer of bedding material and food should be added, and the food should be periodically topped up as the worms process it. Cow manure has been found to be an excellent food. The wormery should not be allowed to completely dry out.

Harvesting the worms manually from the wormery is an involved process but gets easier with practice: material should be removed from the wormery in batches and sifted through to find the worms. As the worms are separated and weighed it is inevitable that some of the material they are living in will remain with them, this is normal and even desirable to avoid causing unnecessary distress to the worms. After weighing the worms should be quickly returned into some bedding material.

To continue growing worms in the wormery, do not harvest all of the worms at the same time. The material the worms are harvested from will also contain worm cocoons, so this should be returned to the wormery after the worms have been harvested from it.



Figure 3. A wormery in Gambella.

Worms in the Toilet

There is nothing physically trapping the worms in the toilet, but they will remain inside the toilet so long as the environment created for them is suitable. One of the most significant aspects of this is ensuring that users flush the toilet with water, but that the drainage is adequate to prevent the bedding layer becoming saturated which will turn it anaerobic. To achieve this the bedding layer and worms must sit on top of a drainage layer, which allows the water to soak away without ever flooding the worms.

In this design the drainage layer consists of a sixty centimetre layer of gravel. Typically, around one kilogram of worms will need to be added to the toilet, and a family toilet will need around one square metre of surface area to support this quantity of worms.

Results of field trials in India show that the toilet will last longer than five years before filling, when emptying may be required.

COMMUNITY MOBILISATION

Ensuring the correct use of a TWT is a much more involving endeavour than for a 'standard' pit latrine, thus a person experienced in engaging with communities must be involved throughout implementation. A comprehensive community consultation process is crucial to give people a sense of ownership and trust in the TWTs.

The worms feeding on the faeces help to reduce bad smell and flies and the toilet will last longer.

Step-by-step community engagement

1. Awareness creation on tiger worm toilets

Prior to construction, community meetings can be held to share information about how the toilet works, benefits and the proposed implementation. These community meetings provide a forum to identify and dispel rumours and myths associated with the latrine (based on culture), and offer feedback to any questions and concerns that the proposed users may have. Depending on the context, it's advisable to have flyers with pictures of the toilets or a demonstration toilet where the community can see the actual structure. Normally meetings with community leaders should happen first, but all members of the community must be involved afterwards: men, women, youth, and people with disabilities.

2. Training of community including community mobilisers to help with follow-up

Community engagement is effective when supported by people from within that community for it to be effective. While creating awareness the team from the implementing agency should identify (with the help of leaders), people that would be good community mobilisers. Typically, these people should be literate, with good communication skills. If community mobilisers are already employed it may be possible to use these for the toilets. Through the community mobilisers, the team should mobilise the community for trainings while construction goes on. Training should be provided directly to users on appropriate use and maintenance of the toilets, including proper explanation of the expected re-use of the by-products.

3. Community forums to train and support proper use

As soon as the construction of the latrines is completed, a handover ceremony to the community can be held. This event can be used for distribution of latrine kits for use and maintenance of the toilets and practical training on how to use them – demonstrations on squatting to use the urine & faeces holes respectively, anal cleansing (if applicable), addition of ash, cleaning excess ash with a broom before leaving the latrine and washing hands with soap as the final step. These community forums should be segregated by sex to encourage users to participate without inhibitions freely and understand proper use of the toilet.

4. Routine follow-up

Through the community outreach agents, both focus group discussions and house-to-house visits can be employed while carrying out routine follow-up on the use of the toilets.

For instance, in a refugee camp setting where 16 households make 1 community (Ethiopia), the best practice is to do house to house visits in the morning (say from 9-12 noon) to observe on-going practices and then conduct a discussion with same HH owners in the afternoon (say 3-4 pm) on challenges they could be facing or areas that need improvement. With appropriate skills and practice, it's possible to

conduct a house-to-house visit within an average of 10 minutes (all 16 HHs will take less than 3 hours) and the afternoon focus group discussions in less than 2 hours.

The routine follow-up should focus on sharing the key messages as well as the proper use of the items provided. For example, tiger worm toilets requires addition of water after every use - the observation during house to house visit should verify if there's adequate water stored in the toilet. Also, the area around the hole should be free from any dry faeces and ideally the latrine should be visibly clean (without smell/ flies).

Key aspects for community engagement

- Provide correct and accurate information on tiger worm toilets including expectations regarding contribution towards construction, operation and maintenance.
- Consult targeted households on the items to be included in the latrine cleaning kits – especially the appropriateness in relation to cultural beliefs.
- The requirements of men, women, young people, children, those with special needs and disabilities in relation to the toilet will be different. Therefore, consult these groups of people and address their needs as much as possible within budget limitations.
- Prioritise the right messages, reinforcing doable, practical and evidence actions, tailored to community member's information gap (based on monitoring over several months of use of the toilets by the community)



Figure 4. A demonstration of how to clean a Tiger Worm Toilet in Gambella.

USER OPERATION AND TRAINING

Tiger Worm Toilet Kit

To facilitate the use of the toilet some items should be distributed with the toilet. These may include:

- a child's potty,
- toilet brush,
- broom or mop,
- a bucket or drum for storing water,
- a cup or small jug for flushing the toilet,
- handwashing container,
- soap for cleaning and handwashing – the cheapest locally available to increase the chance the user will replenish themselves.

Key Messages

Simple messages should be given to the users about how to operate the toilet. A selection of these can be developed into a pictorial guide to be put inside the toilets as a reminder – an example is in the annex. Key messages include:

- Urinate, conduct anal cleansing, and defecate in the hole (not around it);
- Use a cup of water to flush the toilet after every use;
- Use the toilet brush to clean any faeces around the hole to avoid bad smell and flies;
- Avoid using detergents that can kill worms - use plain water to clean the latrine
- Always store water in the toilet for flushing;
- Dispose children's faeces into the toilet – use potties for children who are unable to use the toilet;
- Wash hands with soap or ash after using the toilet;
- Avoid using the toilets for bathing or showering because excess water isn't good for the worms;
- Do not throw solid waste, such as disposable pads, bottles, dry cell batteries, broken glass, metal etc., into the toilet, as these will stop the toilet functioning properly.

MONITORING

Monitoring of the Tiger Worm Toilets can check for:

1. User acceptance and problems users are facing;
2. Are the toilets used correctly?
3. Filling rate, to check the worms are eating the faeces properly
4. Conditions in the toilet, is the environment suitable for worms and how many are inside

The monitoring system should consist of continuous surveillance of the toilets, a systematic survey and focus group discussions.

Continuous surveillance

Community mobilisers will be on the ground continuously, and through their routine visits they will have a good understanding of how the latrines are being used. If the issues they identify can be captured and shared quickly then they can be dealt with in good time.

Systematic Survey

Conducting a systematic survey every three months is useful to establish filling rates, trends and provide clear evidence of the performance of the toilets. Systematically sampling every second toilet can provide representative information. An example checklist that can be used is included in the Annex. If the survey is installed on phones or tablets it is easier to track the data. The checklist does not ask any questions about the users as some people may not be home when the monitoring takes place.

During the survey photos can be taken inside a selection of the toilets to represent normal conditions and outliers. These can be used later to make a visual comparison of how things have changed.

Conducting a survey will typically require at least two people: one to fill in the forms whilst another checks inside the toilets and takes photos.

To understand what is happening inside the toilet, it is necessary to do more than just look inside; a stick can be used to disturb the surface of the toilet to check the worms are present. This stick needs to be safely disposed of inside the toilet.

Focus Group Discussions

A sample focus group discussion template is in the Annex. Given the personal nature of toilet use, focus group discussions should be held in small homogenous groups (men, women, children). Initially focus groups should be held regularly as attitudes and understanding may change quickly and changes are likely to be made as a result. Once the toilets have been established for some time it is easier to include questions about toilets into other monitoring activities, for example into focus groups held as part of an annual knowledge, attitudes and practice study.



Figure 5. Monitoring the Tiger Worm Toilets: Gebre Michael about to inspect the inside of a pit in Gambella.

REFERENCES

Applehof, M., (2003) Worms Eat My Garbage

Furlong, C., Lamb, J., Bastable, A. (2017) Learning from Oxfam's Tiger Worm Toilets Projects, 40th WEDC International Conference

Furlong, C., Gibson, W., Templeton, R., Taillade, M., Kassam, F., Crabb, G., Goodsell, R., McQuilkin, J., Oak, A., Thakar, G., Kodgire, M., Patankar, R. The "Tiger Toilet": From Concept to Reality

Furlong, C., Gibson, W., Oak, A., Thakar, G., Kodgire, M., Patankar, R. (2016), Technical and user evaluation of a novel worm-based, on-site sanitation system in rural India, Waterlines Vol. 35 No. 2

ANNEXES

1. Drawings
2. Bill of Quantities
3. Construction guide
4. Monitoring tools
5. Promotion Materials

A FRONT ELEVATION
Scale: 1:30

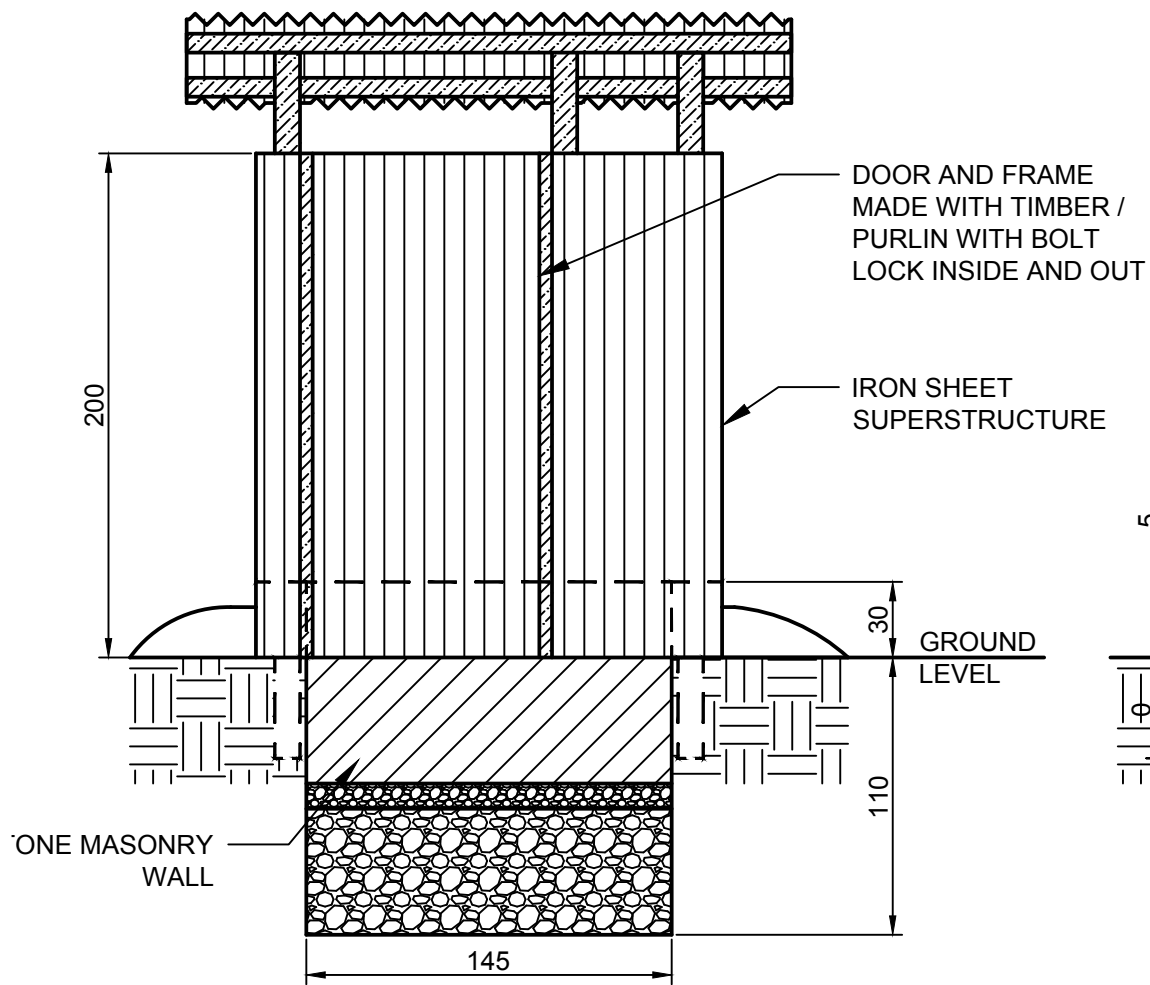

B SECTION ELEVATION
Scale: 1:30

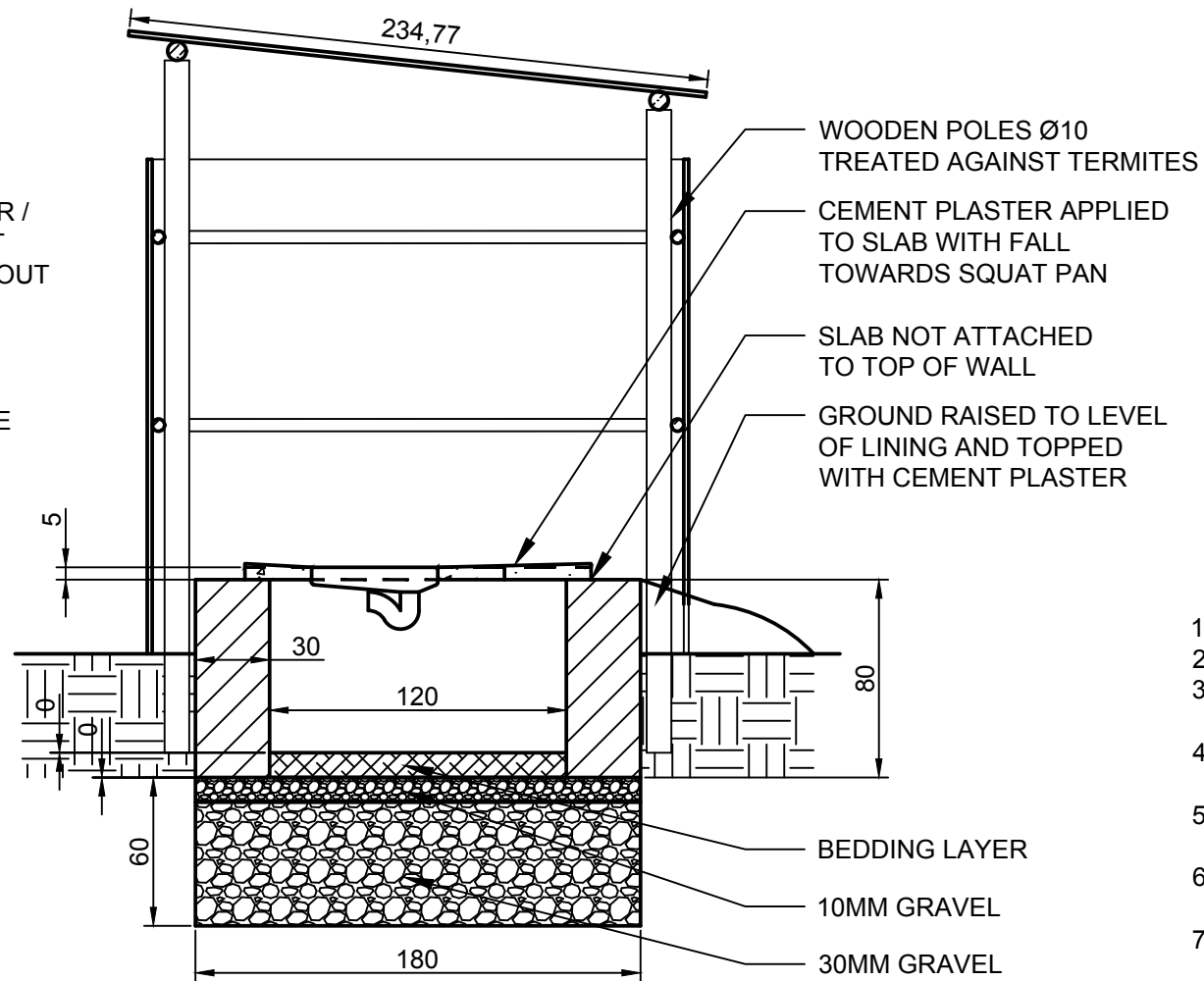

GENERAL NOTES

- DESIGNED FOR 7 USERS
- WORM SURFACE AREA 0.7 SQUARE METRES
- DESIGN FILL RATE IS 30CM EVERY FIVE YEARS
- WOOD CHIP TO BE SOAKED OVERNIGHT BEFORE ADDING TO LATRINE
- 1KG OF COMPOSTING WORMS TO BE ADDED PER TOILET
- SLAB MOVEABLE TO ALLOW ADDITION OF WORMS AND MONITORING
- AMERICAN STANDARD SATO PAN CAN BE USED INSTEAD OF CERAMIC SQUAT PAN

C PLAN EXCL. ROOF
Scale: 1:30

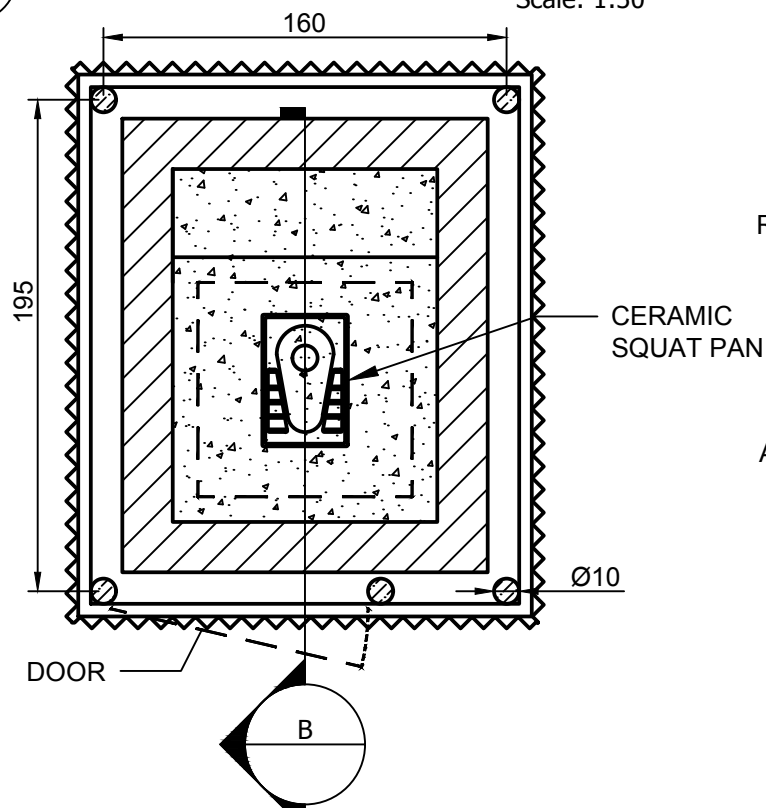

D SLAB REINFORCEMENT
Scale: 1:20

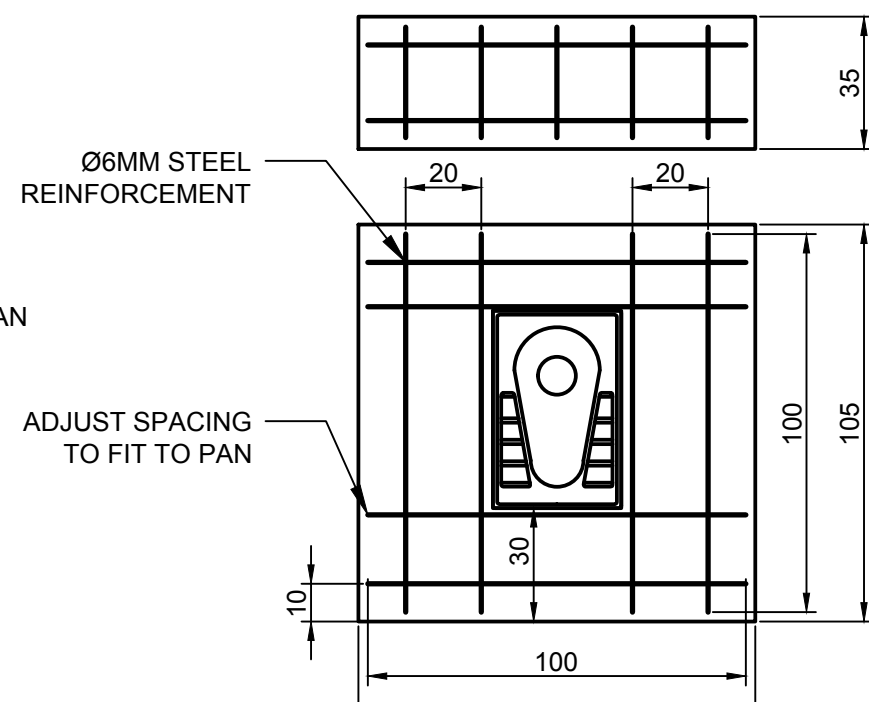

CEMENT AND CONCRETE MIXES			
PURPOSE	VOLUME (LITRES)	MIX RATIO	CEMENT BAGS
SQUAT SLAB	36	1:2:4	0.25
MASONRY MORTAR	250	1:4	2
PLASTER	50	1:4	0.3

	PROJECT STANDARD DESIGN		DRAWN BY ANGUS MCBRIDE	
	TITLE TIGER WORM TOILET		DATE 15-Mar-17	SHEET 1 of 1
	PURPOSE FOR CONSTRUCTION		SCALE AS SHOWN	PAPER A3
	REV 3	ALL DIMENSIONS ARE IN CENTIMETRES		

BILL OF QUANTITIES

Item description	Quantity	Unit
Pit Construction		
Cement	2.5	50kg bags
Sand	0.2	m ³
Gravel Size 10mm	0.3	m ³
Gravel Size 30mm	1.3	m ³
Stone	0.5	m ³
Slab		
Cement	0.25	50kg bags
Sand	0.03	m ³
Aggregate 20mm	0.05	m ³
Reinforcement bar, Ø6 mm	1.8	kg
Binding Wire	0.5	kg
Squat Pan	1	pieces
Superstructure		
Eucalyptus pole Ø80 mm	4	pieces
Timber 50 x 40 x 2000 mm	2	pieces
Timber 150 x 25 x 2000 mm	1	pieces
Burned Engine Oil / Anti Termite Paint	1	litres
Iron sheet, 2 x 0.9 m, 32 gauge	10	pieces
Nails, Roofing	1.5	kg
Nails, 90 mm	1	kg
Butt Hinge, 150 mm	2	pieces
Worms		
Composting Worms	1	kg
Bedding Layer	72	litres

CONSTRUCTION GUIDE

Off-Site Preparation

1. Cast the slab for the toilet off-site. Ensure that when it is cast that it is smooth and level on the bottom. The smaller part has handles so that it can be moved easily for monitoring purposes.



2. If the worms are being housed in a wormery this should be set up on site. This should be in a shady site to prevent overheating. The wormery should have solid walls and be partitioned to allow organising of the worms. Although the wormery needs to be kept damp, it must have a hole to the outside at the bottom to prevent flooding. It should be protected from birds with mesh wire.



3. From the wormery the worms will need to be separated from their bedding material and weighed before they can be put in the pit. Don't start this until you are ready to put them in the pit, but allow adequate time as two people may only be able to process around ten kilograms of worms in a day.



On-Site Construction

1. Dig the pit to the appropriate dimensions. The optimum depth can be determined by infiltration tests on the soil.



2. Fill the bottom of the pit with aggregate. This is the soakaway area, as well as acting as a buffer against particularly high rates of water entry.



3. Construct the walls of the pit from stone with a cement mortar.



- Level the top of the pit, and then place the slab on top. It should fit neatly. Attach the slab using a cement mortar, but leave the access hatch unmortared so that it can easily be opened.



- Erect the superstructure, which should be suitable for the context. If there is a risk of termites in the area, then ensure all poles are dipped in used engine oil.
- Add the bedding layer, ensuring that it has been thoroughly wetted first.
- Add the worms and encourage/instruct the users to start using the toilet straight away.



FOCUS GROUP - MONITORING

General Information

1	Today's Date	
2	Location	
3	Participants (men / women / children)	

Topics for the Focus Group

4	<p>How would you describe the Tiger Worm Toilet to your friends/neighbour?</p> <ul style="list-style-type: none">- Would you recommend it to them?	
5	<p>When you first used the Tiger Worm Toilet did you have any worries?</p> <ul style="list-style-type: none">- How did you feel using the Tiger Worm Toilet?	
6	<p>How is your experience using the Tiger Worm Toilet?</p> <ul style="list-style-type: none">- What do you like about the Tiger Worm Toilet?- What do you dislike about the Tiger Worm Toilet?- How difficult or easy it is to use and why?- Is there anything that you found surprising about the Tiger Worm Toilet?- How does the use of the Tiger Worm Toilet compare with your old toilet?- Do children and elderly use the toilet?	
7	<p>What would you change about the Tiger Worm Toilet to improve it?</p> <ul style="list-style-type: none">- What challenges are you facing while using the TWT?- What do you propose to solve the challenges?	
8	<p>Is there anything else you would like to mention?</p>	

OBSERVATION CHECKLIST

General Information

	Information	Answer
1	Today's Date	
2	Latrine Number	

Look inside the superstructure and answer the following questions

	Observe	Yes	No	Add details
4	Is there water in the barrel for flushing?			
5	Is the latrine clean?			
6	Does it smell bad inside the latrine?			
7	Are there flies in the latrine?			

Look inside the tank and answer the following questions?

	Item	Yes	No	Add details
9	Is there a bad smell when you open the vault hatch?			
10	Do flies come out of the vault when you open the hatch or through the drop hole?			
11	How is the faeces distributed?			Flat across the surface or Cone like
12	What % of the surface is covered by faeces – see diagram below?			
13	Is there vermicompost (worm excreta) present?			Where?
14	Can you see worms, when you agitate the waste with a stick?			Where?

Look inside the tank. What best describes the situation?

	Options	Tick
15	<i>Working. Toilet is in use, worms are inside, vermicompost is visible</i>	
	<i>Not working – flooded. Toilet is in use, whole surface inside pit is covered with liquid</i>	
	<i>Not working – dry. Toilet is in use and is not flooded, but no worms are seen, including after the waste is agitated with a stick</i>	
	<i>Out of use. Owner is away or not using the toilet.</i>	
	<i>Other. Specify:</i>	

Comments / Observations

16	
----	--

TIGER WORM TOILET

THE TOILET HAS HARMLESS WORMS INSIDE WHICH FEED ON FEACES TO MAKE THE TOILET LAST LONGER.

PLEASE GIVE INSTRUCTION TO VISITORS ON HOW TO USE THE TOILET.



POUR WATER INTO THE LATRINE AFTER DEFECATION



**CLEAN THE TOILET WITH WATER ONLY—
AVOID SOAP AND CHEMICALS**



**STORE WATER INSIDE THE BUCKET IN THE
LATRINE**



**WASH YOUR HANDS WITH SOAP OR ASH
AFTER USING THE LATRINE**