

Emergency Sanitation Project

The Emergency Sanitation Project

Phase 2

Final Narrative Report

June 30, 2019



This project was made possible with the support of the USAID Office of U.S. Foreign Disaster Assistance



USAID
FROM THE AMERICAN PEOPLE

Table of Contents

Executive Summary.....	3
ESP Phase 2 Workstreams.....	6
On Site Treatment: Earth Auger, Loowatt and Pelletizer	6
Onsite Treatment: Rapidly Deployable Septic Tanks for First Phase Emergencies	9
Facilitating Construction of Urine Diversion Toilets in Emergency Response	12
Design and Field Trial a Container Based Toilet in Urban Emergency Settings	18
Latrine Lining.....	21
Latrine Superstructures	22
Sludge Reservoirs.....	23
Sludge Screen.....	27
Centralized Treatment: Scaled Up Testing of Chemical Additives for Sludge Treatment	29
Centralized Treatment – Development of the IFRC Aerobic Faecal Waste Treatment Unit for Deployment to Acute Emergencies	33

Executive Summary

With increased urbanization and regulatory scrutiny, the ability of humanitarian agencies to use the simple pit latrine to safely manage human waste in emergencies will decline. When a latrine is not suitable, the response options become exponentially more complicated. Different toilets must be constructed. The contents must then be removed and treated. This is as complicated and expensive as it is important for the health of disaster affected populations.

In those rare instances that humanitarian agencies attempt to address the significant and increasing need to manage faecal waste, the response is usually incomplete. Apart from the later stages of the Bangladesh Population Movement Operation (PMO) in Cox's Bazaar, Bangladesh Faecal Sludge Management (FSM) is usually limited to collection, desludging and uncontrolled dumping, causing serious environmental and public health risks which increase human suffering and the cost of humanitarian response. Even in the Bangladesh PMO, progress on FSM was extremely slow with relatively simple options taking months to establish. The WASH sector needs to get better and faster at providing FSM.

The Emergency Sanitation Project seeks to provide the WASH sector with greater access to rapidly deployable equipment, designs and methodologies for the entire FSM chain, from toilet to treatment. The first phase of the ESP tackled a number of challenges in providing sanitation in difficult contexts. Some of those initiatives failed or were resolved. Others showed promise and needed refinement and field testing. In its second phase, the consortium focussed more narrowly on the FSM chain and tried to bring solutions identified in Phase 1 closer to being field ready.

The key areas investigated in ESP Phase 2 were:

- Toilet Design
 - Rapid Latrine superstructures
 - Design and field trial non-toilet option in urban emergency settings
 - Latrine lining
- Onsite treatment -
 - Urine diversion dry toilets (UDDT)
 - Testing of onsite treatment technology
- Latrine emptying and desludging
 - Improving Previously Tested Desludging Technology
- Centralised excreta disposal
 - Sludge Reservoirs
 - Sludge Treatment

Onsite treatment can offer many benefits to a faecal sludge management programme, most notably the reduction or even elimination of the need for sludge transport. WASTE conducted a field trial to determine the acceptability and appropriateness of earth auger and Loowatt toilets mounted in a locally manufactured raised latrine. The earth auger performed well, with good results on sanitization and stabilization. Oxfam also carried out onsite treatment technology trials and upgrades to toilets for sludge collection.

The Netherlands Red Cross joined the consortium that worked together in the first phase of the Emergency Sanitation Project with the principle aim to work on transfer stations for faecal sludge. A survey of main stakeholders led to the creation of a list of functional requirements and then a request for tender for transfer stations was made. The call resulted in the selection and development of a steel tank and a modified bladder. Design sessions were organised to ensure good understanding of the design criteria and possible solution to optimize the final design.

Simultaneously several experts were contacted about the problem of solids and sharps in faecal sludge. A technical study was conducted on the matter, which led to the design of a prototype for a mobile bar screen. This sludge screen can be put before the pump or bladder to remove the solids and sharps from the sludge.

The materials were tested by consortium partner WASTE in Blantyre, Malawi. The trials are considered successful and it is recommended to expose the two reservoir designs to more testing with different sludge types to further improve the design and possibly to start a pilot in a real emergency setting. While the concept of the bar screen worked out well, a stronger version that can resist larger pressures and which is easier to open for cleaning needs to be developed. A design that can resist stronger pressures would also function at the outlet of a pump. We see all three products as promising innovations in the emergency sanitation sector for specific setting and will look with sector partners to further develop these solutions.

WASTE and its sanitation partners also carried out research to determine whether commercially available additives can stabilize and sanitize faecal sludge. The initial finding in ESP Phase 1 indicated that chemical additives were efficient in terms of pathogen reduction and organic matter decomposition. As the Phase 1 testing was done at lab and small scale, the present research aimed to determine the treatment effectiveness of lime, caustic soda and urea in 2000 litre storage tank. When using chemical additives such as lime, soda and urea, rapid stabilization and sanitization of faecal sludge is most likely to be achieved when they are mixed. Because of the type of sludge used on the test the mixing process, which used a membrane pump, was difficult and required multiple mixing sessions. Significant reduction in concentrations of E. coli was observed in faecal sludge treated with additives of chemical origin. Lime also reduced the pathogen concentration faster than caustic soda. While lime and urea brought pathogen levels down to acceptable limits in one day, caustic soda demanded three days to reach the recommended level.

In 2018 a pilot of the new IFRC Aerobic Faecal Waste Treatment Unit was initiated in the Bangladesh Population Movement Operation to safely treat sludge and waste water. The unit uses novel technology to deliver a tried and tested treatment process. While the pilot is small and has experienced a number of setbacks, the unit performs beyond our expectations and delivered proof of concept. Further improvements to the system are being made and planning

is underway for additional testing in contexts outside of Bangladesh. The treatment plant is accompanied by a faecal sludge field laboratory, itself an innovation driven in large part by the ESP, which has been monitoring the effluent quality of the IFRC treatment plant. As we refine the equipment and build the pool of technical profiles to operate them we will increasingly ensure the communities we serve, along with our own field hospitals and base camps, will be able to dispose of large quantities of wastewater safely.

ESP Phase 2 Workstreams

On Site Treatment: Earth Auger, Loowatt and Pelletizer

Background

On site treatment has the potential to reduce or even eliminate the need for sludge transport. A number of technologies are available for onsite treatment. While field trials of this technology have been carried out, it was unknown how the use of chemical additives would affect their performance.

Work carried out in Phase 2

Two Loowatt toilets were trialed to test the acceptability, appropriateness and on-site treatment capacity when installed in raised latrines. The Loowatt toilets were tested at Fount of Victory Church during the days the church had services, with a range of users between 100 to 500 users per day. The church usually had the main services on Thursday evening and Sunday afternoon. Faecal sludge collecting tanks were emptied weekly or more often depending on the frequency of users at the church.

The toilets were applied with Urea at the plastic bag that collected the faecal sludge. No mixing process was applied. The Loowatt toilets were mounted on a raised latrine that was manufactured locally with the use of metal sheets



Loowatt Raised Latrines tested at Fount of Victory Church in Blantyre

Four earth auger units were tested at Namisu Orphanage in Blantyre with users ranging from 10 to 20 users per day. The first unit was set as a control unit where ash was used to enhance the decomposition of faecal matter and in the other three units ash was combined with lime, urea and caustic soda. Each unit was used from 10 to 20 people per day.



Earth Auger Toilets at Namisu Orphanage in Blantyre

In addition to the two onsite treatment toilet units, the team also tested a pelletizer as post treatment of faecal sludge. The unit was procured and tested in Blantyre with compost manure.



Unpelletized Compost Manure (left) and Pelletized Compost (right)

To produce the pellets, the material being pelletized is moisturised and then put into the pelletizer after making sure that all stones and metals are removed. The produced pellets are tested for microorganisms and chemicals to make sure that they are safe to use. Some of the chemical tested include the levels of Potassium, Nitrate and Nitrite Nitrogen and phosphorous. In microbial analysis, E. coli, Enterococcus and Salmonella are analysed.



The pelletizer

Results

As with the chemical treatment workstream, the contents of the onsite solutions were tested for a number of parameters. Although there was a 40% reduction of pathogen concentration in the Loowatt toilets after one week of treatment process, it was not enough to reach the limits recommended by WHO guideline. Furthermore, there was no significant reduction in the concentration of organic matter. Consequently, the faecal sludge collected on the plastic bags of the Loowatt toilets could not be stabilized.

On the four earth auger units tested a reduction on pathogen concentration in all units was identified. In two units (control and lime) pathogens could not be identified after one week of treatment. In the units where caustic soda and urea were applied, the pathogen reduction was not enough to reach the recommended limits. The samples analysed reached the organic matter reduction required to identify the sludge as stable in all four units tested. Additionally, no flies and odour were identified.

Treatment effectiveness of the pelletizer was unclear. However, in terms of marketing, clients were willing to pay 50% more for compost when it was pelletised. This margin was due to presentability and ease of transport. This may not be a long-term solution as the pellets will not perform better than pure compost. This will reduce the farmer's already small profit margins and they will only buy the product once. It was also felt that the maintenance and operational cost of this machine will struggle to justify the value created. The grinding wheels required replacement and other pieces needed repair after the unit produced only about 300kgs. Faecal sludge treatment will really struggle with a small machine like this one, particularly when more sand and stone are present than in compost.

Next steps

We aim to see if an earth auger toilet can be used in an emergency setting, such as a refugee camp welcome centre.

Onsite Treatment: Rapidly Deployable Septic Tanks for First Phase Emergencies



Background

In rapid on-set emergencies where large numbers of people are displaced agencies first set up communal latrines. Where there is space and the ground allows, trench latrines are still the cheapest and quickest option. However, with increasing number of displacements happening in situations where it is impossible to dig trench latrines due to rocky or water-logged ground, lack of permission from landowners and lack of space or lack of access for desludging it is becoming more frequent for raised latrines to be used. After the Haiti earthquake, Oxfam and other agencies had to build huge numbers of raised latrines in the urban areas, each cubicle had 50+ users, the slabs were direct drop and people took in containers of water for anal cleansing. Each cubicle had around 1 m³ containment beneath it and had to be desludged once every 4 days. The cost of a desludging tanker at that time was around US\$150 for 4m³ resulting in substantial ongoing operating and servicing costs of toilets. Lowering the desludging frequency to once a month would have saved US\$ 750 per month for each block of four latrines

Past initiatives to deploy compact treatment units have been vastly expensive, and a previous attempt to make a flat packed septic tank failed as it was too fragile. Urine diversion and tiger worm toilets are suitable in difficult ground conditions but are not suitable or appropriate at scale for 1st phase communal toilets where a rapid set up is required and the users are between 50 and 100 people per toilet.

Work carried out in Phase 2.

Oxfam identified Bremen Overseas Research and Development Association (BORDA), a German based NGO specialising in decentralised sanitation solutions, as the most appropriate technically qualified partner to co-create a modified prefabricated Septic Tank Kit system for the rapid on-site application in emergency camps. In November 2017 a 1-day scoping workshop was held in Germany which developed the following requirements for the product:

- 1) Safely collect, store, treat and dispose of faecal wastewater from shared water-born toilets used by 300-500 people per day. It is envisaged that toilets could be direct drop or pour flush, with several cubicles (serving 50-100 people) connected to each septic tank.
- 2) Ensure the treatment of the faecal wastewater to the quality required for disposal via ground infiltration, vegetative leach field or sewer drain.
- 3) Optimise sludge storage to reduce the frequency of desludging.
- 4) Be designed in a kit system in a way that can transported by airfreight, be easily assembled within one day, and be operated for a period of up to 12 months.
- 5) Consist of durable pre-fabricated elements that are available on the international market with a potential to be manufactured locally.
- 6) The system should be suitable in all climate regions and for different sanitation cultures (washers and wipers) without requiring modifications and adaptations
- 7) Require an excavation depth less than 1.2 m.
- 8) To prevent legal conflicts the system should only consist of non-permanent structures, which can be easily removed when they are no longer required.

The [feasibility study](#)¹ concluded that a bladder-based construction was most appropriate material. BORDA engaged an industrial partner (GENAP) to manufacturer.

To date there have been 3 stages of trials:

GENAP factory – Netherlands. This initial field trial was undertaken jointly between Oxfam, BORDA and GENAP in Netherlands in June 2018. The septic tank bladder was laid out and filled with water to provide an initial indication of functionality. This identified the need to modify the desludging pipe system and highlighted a possible weakness of gas tight zips as a means of accessing inside the septic tank. More details are attached in this [report](#).

Bremen Sewage Treatment Works - Germany. Following some minor modifications, a more extensive, 3-week duration pre-field deployment was undertaken by BORDA at a sewage treatment works in Bremen where the performance of the bladder was tested with sewage. On



¹ For a version of this report with active hyperlinks, please visit www.emergencysanitationproject.org

the basis of this successful trial, two complete septic tank kits were manufactured for deployment in an ongoing emergency. See attached [time lapse](#) for more details.

Oxfam Supply Centre, UK. As part of a technical learning forum for Oxfam's global surge team of engineers, BORDA was invited to UK and the complete septic tank kit was unpacked and partially set up within the Oxfam warehouse. [Feedback](#) was generally very positive but a number of observations and suggestions have been made on further improvements and how to optimise the kit as and when it is turned into a commercial product.

Results

Pre-field trial in Germany has verified the integrity of the unit as well as the technical performance. Ultimately confirmation that it is fit for purpose can only be determined as a result of a live deployment and active field trial.

One unit has been sent out to Bangladesh for deployment in Cox's Bazar. A suitable site has been identified but complex import restrictions have meant that it has taken several months to get the unit to Bangladesh². Oxfam and BORDA are still discussing a second location, most likely Northern Iraq, to test the second kit.

Unfortunately manufacture of the kits was several weeks too late to have been considered for Mozambique (Cyclone Idai response), which would have been the perfect context for deployment due to the flooded areas and high-water table preventing digging of latrines.

Next steps

This workstream was only initiated in phase 2 of the Emergency Sanitation Project, it has been difficult to complete all stages of product development from concept, feasibility, manufacture, pre-field testing, field testing then lopping back to make any necessary modifications for a final product.

Field trials will be completed beyond the ESP with alternate funding.

BORDA has confirmed its interest to commercialise the septic tank kit. This requires further work with an industrial partner. The price point of the unit is still an area Oxfam and BORDA are working on to bring it to a price that is as competitive as possible. Cost effectiveness needs to be judged by consideration of both capital and recurrent costs (which humanitarian responders and donors frequently overlook).

² At the time of writing it had still not been cleared through customs.

Facilitating Construction of Urine Diversion Toilets in Emergency Response

Background

For difficult ground conditions where it is not feasible to construct pit latrines (rocky, collapsible, flood prone areas), it is increasingly being recognised that urine diversion dry toilets offer the best solution. As a result of operational research over the last few years led by Oxfam, UNHCR has decided to adopt urine diversion dry toilets (UDDTs) as a preferred solution for such ground conditions. It is therefore expected that UDDTs will account for a growing proportion of latrines built in camps in future. Whilst UDDTs are proven for the transitional period of a humanitarian response as the emphasis shifts from communal to household latrines, their use in the early phase of a response has not been widely tested. This ESP workstream aimed to develop equipment that encourages rapid adoption and scale up of UDDTs at earlier stages of a response by developing:

Product 1) A plastic insert that fits on top of an existing keyhole slab transforming it into a urine diversion toilet* (first phase where pit latrines are not viable).

Product 2) A plastic insert which can be fixed to a concrete slab or timber platform (first phase or transition).

Product 3) A mould to enable high quality concrete slabs and UD inserts to be produced (transition phase to household latrines).

* Consultation with field engineers and industrial partners ruled out developing a self-supporting emergency UD squat plate, and this approach was considered much more cost effective.

Work carried out in Phase 2.

We decided that there were existing commercially available plastic squat plates (product 2) so rather than duplicate, a desk-based study was done to identify which is most appropriate. This resulted in 10 UD inserts being procured from Sanergy³ and trialled in Ethiopia. Feedback is [attached](#).

³ Sanergy is a Kenya based social enterprise which operates a toilet franchising and servicing business covering over 3,000 UD toilets. They undertook significant research prior to designing their own urine diversion squatting plate. Oxfam decided to trial Sanergy squat plates based on the well tested and proven functionality of these toilets in Kenya.



Following an expression of interest, Oxfam selected Dunster House as an industrial partner to develop the products 1 and 3. During the process, it became apparent that the specification for Product 1, also meets the requirements of product 2, as the need to fit within the dimensions of a keyhole does not significantly compromise the sizing or functionality of either the urine basin or faeces drop hole.

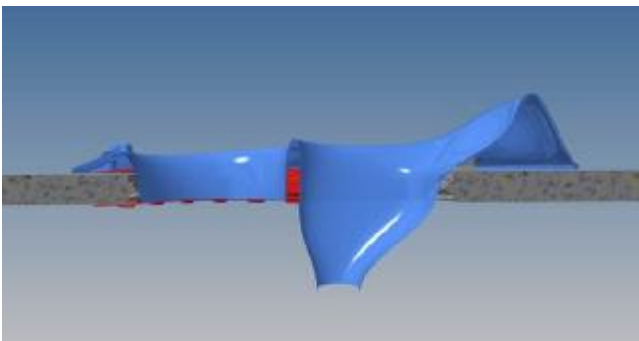

Temporary wooden moulds were fabricated for production of prototypes using vacuum forming. This was considered to be the most cost-efficient manufacturing process for a limited production of prototypes. A total of 31 plastic squat plates and 11 moulds were produced before the moulds became spoiled.

Production of prototypes took considerably longer than anticipated. Dunster House was open with Oxfam during the supplier identification stage that their consultancy rates were calculated and offered on the understanding that their commercial priorities would always take precedent over this project, so target delivery dates would be soft and open to slippage (which Oxfam accepted).

The plastic squat plate is compatible with both the NagMagic emergency keyhole slab (which is the most common emergency squat plate used in humanitarian responses as well as the Dunster House squat plate (that the Oxfam Supply Centre currently uses). A [bracketing system](#) which fixes to existing threaded bolt holes present in both squat plates, secures the UD insert in position with plastic spaces used to accommodate the different thicknesses of each slab. A rubber gasket ensures a tight seal between the insert and the underlying slab.



The squat plate was also compatible with a number of other slabs. Key compatibility considerations are the same size of keyhole and footrest configuration. If the keyhole is smaller or the gap between footrests narrower, then the insert is unlikely to fit. Whether existing bolt holes are not present within the self-supporting keyhole slab, the brackets are not required and would be replaced by drilling hole through the slab and securing with a bolt and nut from above

and below. This same method would be used for a timber or concrete floor. This [instruction sheet](#) provides more details on the squat plate and installation process.

Challenges were faced in production of the UD mould (Product 3) due to limitations of the manufacturing process. Vacuum forming stretches a piece of plastic onto a mould. The greater the depth of the mould the further the plastic needs to stretch and consequently the thinner and weaker it becomes. The urine basin was designed with a steep front lip to fully contain urine and prevent overflow (see below CAD drawing). This had to be reduced to retain the strength of the mould. This [instruction guide](#) illustrates the production process.



Results

Prototypes were sent to Uganda, Tajikistan and Ethiopia.

Tajikistan

Urine diversion slabs were offered to a school and a water user association and discussed with several stakeholders. Ultimately, to date, only a single location has installed a UD slab as there was a clear preference for sato pans, which Oxfam has also been promoting. Concerning preparation of UD slab, it is very easy to mix, pour cement to the mould and separating the mould from ready product, there was not any problem with the construction process. However, WUA

members have not been regularly using this toilet as they prefer SATO pans. The main stated reason is the difficulty of waste management and cultural barriers.



Ethiopia

Feedback from the Ethiopia is attached here.

Oxfam in Ethiopia has constructed over 1,000 double vault UD toilets in the last 5 years. The mould enabled higher quality UD slabs to be made which were nicer in appearance, preferable to users, easier to clear and simpler, quicker and cheaper to produce. The main challenge was in retrofitting the squat plates (plastic and concrete) to existing toilets, as for the urine hole to align with the existing urine pipe in the midpoint between the two alternating toilet chambers resulted in the drop hole being very close to the dividing wall, which is likely to prevent the chamber from filling fully. The problem could be avoided by making slight adjustments to the urine pipe by adding an extra length of pipe, which would enable the drop hole to be located in a more central location.

Uganda

Unlike in Ethiopia where double vault permanent household latrines are being built with concrete floors, for Uganda South Sudanese refugee response, agencies are still using plastic emergency keyhole slabs which provided an opportunity to trial the performance of the plastic squat plates. Both plastic UD squat plates and moulds have been sent to Uganda but due to the late completion of manufacturing, compounded by the time required for shipping and customs clearance, results are still pending. The ESP website will be updated accordingly.

Initial feedback based on observations of the Oxfam technical team are as follows:

- 1) The bottom of the urine funnel should be sized to be compatible with a 1 or 1.5 inch standard PVC fitting to simplify drainage of urine.
- 2) The concrete squat plate urine basin needs to be larger to compensate for front lip not being higher. This will result in increasing the dimensions from 60 x 60cm to 80 x 60 cm

Next steps

In light of the above feedback Oxfam is reviewing the design of the concrete mould. Firstly, the urine basin will be enlarged and secondly, we are reviewing whether as part of this is desirable to design the permanent concrete squat plate to fit the UNHCR approved UDDT specification and recommend a single standard design for semi-permanent UDDTs which should always be based on double vaults designed with adequate retention time for pathogen die off.

Oxfam plans to issue an expression of interest to identify an industrial partner to commercialise both products. Initial discussions indicate that vacuum forming remains the most appropriate process and with production of a resin mould could meet the anticipated initial demand (1,000-5,000). Should there be a greater demand than this rotomoulding or injection moulding would be the next step.

Design and Field Trial a Container Based Toilet⁴ in Urban Emergency Settings

Background

In its crudest form containers are widely used in camps to meet the needs of people who for a variety of reasons do not use or are not able to access sanitation facilities available. Over the last decade interest has grown in container-based sanitation (CBS) as a cost-effective scalable solution in high density urban areas where there is a lack of space to build toilets. Oxfam has been at the forefront of this in relation to its work in urban informal settlements in Kenya since 2010.

CBS has been piloted in displacement contexts on a small scale⁵ but it remains a niche area. A number of CBS organisations focus on waste to value initiatives⁶ although based on narrow economic analysis⁷ none are currently economically viable. Research clearly shows that a significant proportion of disaster affected people do not use the communal sanitation facilities that humanitarian agencies provide. Individual or shared household latrines immediately adjacent to dwellings typically address the barriers that communal toilets pose, however, it is rarely possible to construct these in the early stages of a response. A significant number of people living with special needs (PSNs) are not able to use shared communal or household latrines. HCBTs could provide a rapid solution to ensure PSNs and wider camp population has access to a toilet in their home or within immediate access to their dwelling.

In ESP phase 1, Oxfam supported a Kenya based partner to trial the mo-san (container-based toilet) in Kakuma camp. In parallel with ESP we organised a [toilet summit](#) attended by leading organisations in the field of container based sanitation (CBS) and developed a household level [container based toilet](#), known as the [iHUD](#) (in-home urine diversion) toilet.

Work carried out in Phase 2.

Under ESP2 the iHUD has been re-designed to make it suitable for the humanitarian market – namely to simplify the production process, redesign the toilet to make it lighter, nestable and stackable for efficient transport, easier to service and empty and ultimately reduce the unit cost. This work has been led by Sanergy, a Kenyan based social enterprise who provide a toilet provision and servicing franchise within urban low-income settlements.

Sanergy had introduced the iHUD into their business model under the brand name “Freshfit” to complement their core business of public pay toilets, known as “Freshlife”. The above mentioned design issues are equally relevant to a displacement setting as they are to an urban slum.

A more detailed write up of activities and findings carried out during this project is include [here](#).

⁴ This was previously referred to as “no toilet option” in the proposal.

⁵ Most notably by Sanivation in Kakuma refugee camp, Kenya.

⁶ Organic compost, animal feed, biogas, fuel briquettes.

⁷ Without considering a holistic approach and the health and environmental implications and costs of poor sanitation

Following a consultation process with existing users of the iHUD and service operators who collect, empty and clean toilets, the following design modifications were made:

- i) urine tank enlarged (from 16-24 litres capacity) and modified to simplify cleaning and enable stacking (10 tanks can be stacked to improve ease of distribution and collecting).
- ii) urine funnel modified for improved nesting of bodies



Using this revised design, a fully functional prototype was 3 D printed and field trialed in Mukuru settlement, Nairobi.

The field trial identified that the toilet hinge was a weak point and the rim at the base of the toilet made it unsuitable for uneven ground.

The Sanergy team used [virtual reality](#) as part of their marketing approach to illustrate to potential customers about the benefits of owning an iHUD.

Results

3-D printed toilet was produced and field trialed.

A final CAD design has been produced based on all the feedback and constraints identified.



Next steps

Sanergy sees the value of the iHUD for its own business and is committed to setting up production of the improved iHUD in Kenya for its own “Freshfit” enterprise. Sanergy is confident it can resource this initiative and is currently in the process of obtaining quotes for manufacture of moulds to enable mass production of the iHUD. This will be achieved through a combination of rotomoulding (for the urine tank) and injection moulding (for the lid and toilet body).

It is anticipated that by September 2019, the final iHUD will be available to buy.

Oxfam is initially looking to trial this as a solution both for people with special needs who struggle to use existing camp sanitation facilities and as an option to speed up the transition to household toilets for women who do not feel safe accessing communal toilets.

Latrine Lining

Background

Construction of latrines in loose ground formations where soils are prone to collapse presents health and safety dangers to those involved with excavating toilets as well as users themselves in the long term. Use of liners provides a solution but significantly adds to the cost of each latrine. ESP phase 1 tested several types of trench latrine liner in UK and South Sudan.

Work carried out in Phase 2.

ESP2 had initially intended to continue where ESP1 had left off. We started by engaging with Dunster House and Even Products, two existing suppliers of liners to understand costs and demand for their products which were tested in ESP1. In parallel we engaged with our Procurement centre and field engineers to understand whether there was a demand for trench latrine liners and whether they viewed liners as a need.

At least one supplier was willing to improve the liner that they have developed during ESP Phase 1 but they expressed doubts about the demand from agencies and the commercial worth of investing time and resources on such a product.

Consultation with field engineers highlighted that the low demand for lining kits is due to 3 main factors i) high cost, ii) time delays in getting equipment shipped and cleared through customs, and iii) availability of local materials and locally improvised solutions. On further consideration it was decided that a more appropriate piece of work would be to develop a technical brief capturing the range of options for providing sanitation in areas of loose collapsible soils. This freed up project resources to enable the Septic tank workstream to be included within ESP2 which hadn't been originally budgeted.

Results

[Technical brief – Latrine lining and sanitation options in unstable ground.](#)

Next steps

No further work is planned.

Latrine Superstructures

Background

Under ESP1 Oxfam assessed a wide range of latrine superstructures, narrowing it down to two preferred designs – Dunster House and Flexxolutions. This resulted in a tendering process which selected [this](#) preferred superstructure, as the most cost effective, balancing affordability and functionality. It is available through the Oxfam International Supply Centre. During this process Oxfam became aware of additional designs which was open to considering

Work carried out in Phase 2.

A quick informal re-evaluation was undertaken engaging with several existing suppliers and involving a consultation with British Red Cross who had also done their own research on latrine superstructure. Similar findings emerged from suppliers and field engineers to that of latrine liners – namely demand is low due to high cost, time and delays due to shipment and clearance and local materials/local solutions generally being available in-country.

We explored the need for a rapid “pop-up” superstructure, but the costs of a tent type toilet, although quicker to erect, was actually more expensive than existing superstructure kit Oxfam had already identified in phase 1, which although slightly slower to assemble, was significantly more durable with better functionality and user privacy.

Consequently, the workstream was terminated and resources redirected to the septic tank workstream.

Results

Nothing to report

Next steps

No further work is planned.

Sludge Reservoirs



Background

As an outcome of the work done in ESP Phase 1 and experiences in several emergency responses, the need to have a reservoir specifically designed to store faecal sludge has been repeatedly identified. Reservoirs currently available on the market are not always suitable for sludge storage, as sludge from pit latrines is often mixed with different kinds of solids such as stones, leaves bottles etc. Previous experiences with sludge in commonly used reservoirs showed that outlets are easily blocked, reservoirs are difficult to clean and solids in the reservoirs can easily damage the liner. While work was also carried out to identify options to reduce the amount of solids entering a reservoir (see Sludge Screen), development of reservoirs that, amongst other criteria, are strong, puncture resistant, easy to transport and construct, easy to clean and control odours and insects remained a gap that needed to be addressed.

Work carried out in Phase 2

The Netherlands Red Cross established design criteria for sludge tanks after consultation with a number of experts and a literature review. Important criteria included:

- smell and insect control,
- durability and puncture resistance of material,
- possibility to transport (by air),
- ease of and access for cleaning
- ease and speed of set up,
- and large outlet to prevent blockages.

An international market study was conducted with several international suppliers of reservoirs and suppliers known to the emergency world contacted to discuss design criteria for the sludge reservoir. The study included a small research in advantages and disadvantages of the different liner materials. Suppliers were then invited to come forward with ideas and proposals. The results were then shared and evaluated with the assistance of an external consultant and innovator in the sanitation sector.

Rather than simply select one option, a design workshop with a few selected suppliers was organised to discuss the requirements, proposed design and possible innovations. After that workshop a small selection of equipment was purchased for testing in Malawi. The trial tested a one metal reservoir and one sludge bladder. The reservoirs were tested in conjunction with the sludge screen. The field trial was conducted by WASTE in Malawi using real faecal sludge.

Two different sludge reservoirs were developed and tested in Malawi. One of the reservoirs was similar to the well known Oxfam tank, but, amongst other differences, this tank has an outlet at the bottom of the tank. The other reservoir tested was similar to a common bladder. The sludge bladder is made of a material that is selected on the bases of durability, flexibility and resistance against tearing and punctures. To prevent the inlet or outlet to get blocked, a 6-inch outlet was fitted, while a 500mm manhole opening was fitted on the top of the bladder to facilitate cleaning. Sleeves were fitted for easy handling and support emptying and cleaning. One outlet was fitted on the corner of the bladder so remaining liquids can more easily be drained from the bladder. The bladder was delivered in a small size (5m³) for testing purposes. The product was tested in Malawi by WASTE Foundation and WES.

Results

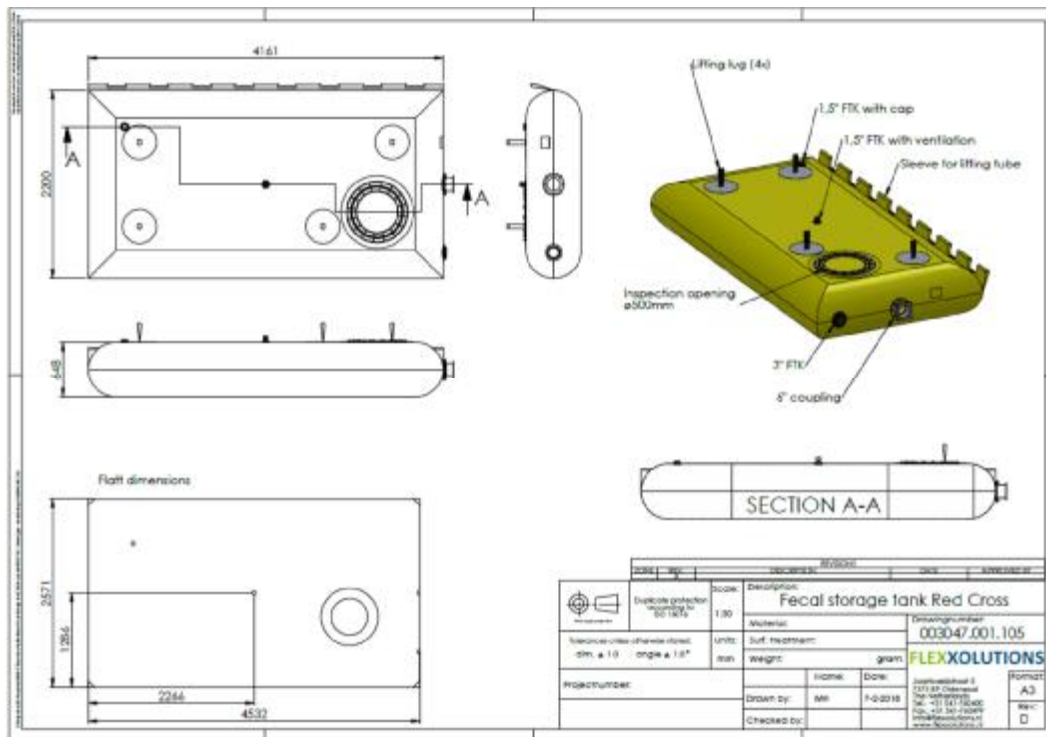

Bladders do have the advantage to be easily transportable and quick and easy to set up, but they are difficult to clean and vulnerable for leakages. When solids are entering the bladder they can be extremely difficult to get out and increasing the risk of punctures during transport. The large 6 inch opening of the bladder worked well with the sludge used. No blockages were observed during the testing. The manhole is useful for cleaning of the bladder before transport or packing. The bladder is easy to transport and set up, so has the capacity to be deployed rapidly. It is easy to fill and empty with the correct couplings. As the bladder is a closed reservoir

even if the sludge stays for a long period in the bladder, there was no offensive smell or attraction of insects. The bladder is vulnerable to damages due to vandalism or during transport and must therefore be carefully overseen and monitored. The bladder must be placed in a flat terrain without stones or sharp objects that can damage it. Small leakages or damages are easy to fix with a repair kit or superglue. Sleeves are useful to manually drain remaining sludge or liquid towards outlet.

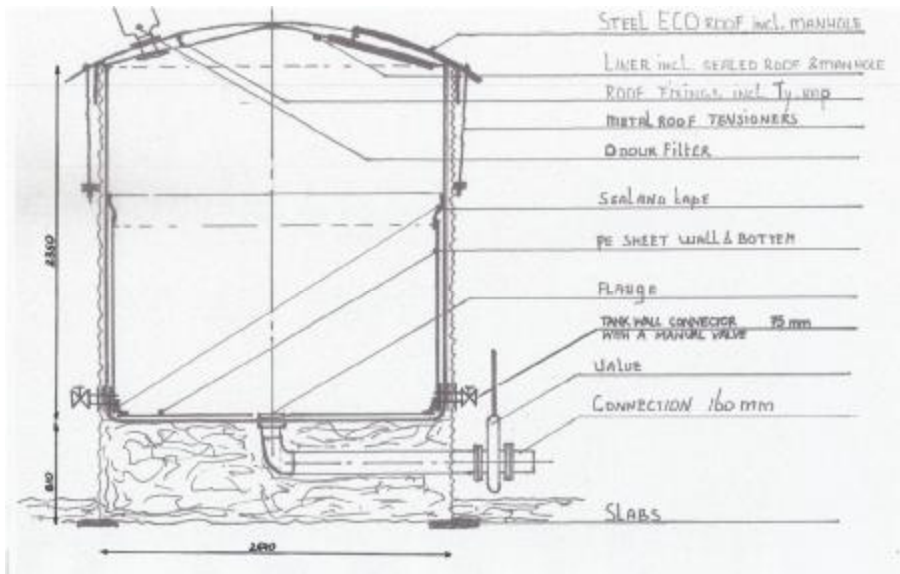

Outlet of tank



Top view of roofing



First level of metal sheets filled with sand



Liner after use

As the corrugated steel tank was delivered without a manual, the initial installation was slightly difficult. After understanding the principles of the construction and the labelling of the metal sheets, construction was easy and can be completed within a day by a team of 4 to 6 people. Dismantling and reinstallation is possible, but the reservoir is most suitable for longer use in one location. No problems with the liners and roof were observed during the testing. The metal roof was not used during the test. The roof did close well enough to prevent smell and prevent easy access by flies. The 160mm bottom outlet did function well which does facilitate safe and easy cleaning. A mesh to protect the outlet was not delivered as discussed with the supplier, but it is advisable to add this option and install a bottom wall outlet as backup to prevent the outlet from getting blocked.

Next steps.

It is envisioned that WASTE will be able to use both reservoirs over a longer period in its programming in Malawi, so more results on the durability of the reservoirs will be known. Results will continue to be shared with the sector.

Sludge Screen



Background

During previous trials in Malawi solids and trash mixed in the sludge caused serious problems with the desludging, with textiles and large solids blocking the pump and reservoir inlet and outlet. To prevent larger solids entering the pump and sludge reservoir and thereby protect the reservoir from damages from sharp objects a sludge screen is needed.

Work carried out in Phase 2

The Netherlands Red Cross began work to develop such a screen by contacting a number of suppliers of different sludge pumps for ideas. After consultation, SowTech designed and constructed a prototype of a mobile sludge screen. The screen is designed to be put at the inlet side of the pump to protect the pump itself. The size of the screen can be changed to allow small items to pass and prevent the screen from getting clogged too often. As the prototype of the screen cannot handle large pressures it could not be fitted on pump outlet. A manual with all design parameters and detailed test protocol was delivered with the unit. The sludge screen, tested in conjunction with the reservoirs, was placed before a vacuum pump and used by WASTE to empty pit latrines in Blantyre, Malawi in early 2019.

Results

The screen was able to prevent rubbish from passing into the pump. Items that were caught by the screen included maize cobs, newspapers, condoms, plastics and pieces of cloth. As there was a lot of rubbish in the latrines deslugged in this trial, screening 1,000 litres of sludge through the screen took about 20 minutes. Dismantling of the screen in the field can take 15 minutes while cleaning of the screen took an additional 30 minutes during the pilot. However, the manual shows it can be done easier, so it is expected that with more experience cleaning can be done much faster. The screen does increase the time to empty latrines. However, this eliminated the need to repair or unblock the pump, saving time overall and avoiding damage to the pump and reservoir.

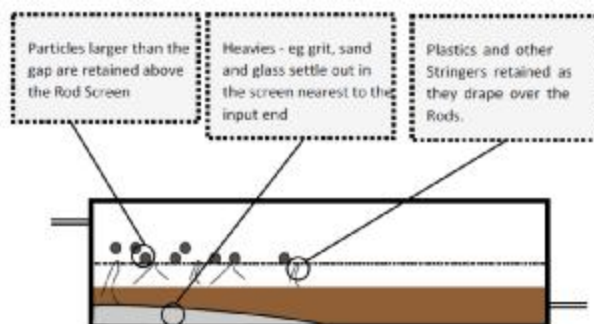

How the screen works

Emptying toilet sludge using the screen has proved to work efficiently. The principal idea of the screen works fine. With pit latrines that contain a lot of rubbish manual fishing remains needed, as the screen will get blocked with large amounts of rags, clothing etc.

Next Steps

Dismantling the whole screen requires much time and effort. There is a need to develop an easy way to open the unit and clean the screen more rapidly. A stronger version will also need to be developed so that it can also function at the outlet of a pump.

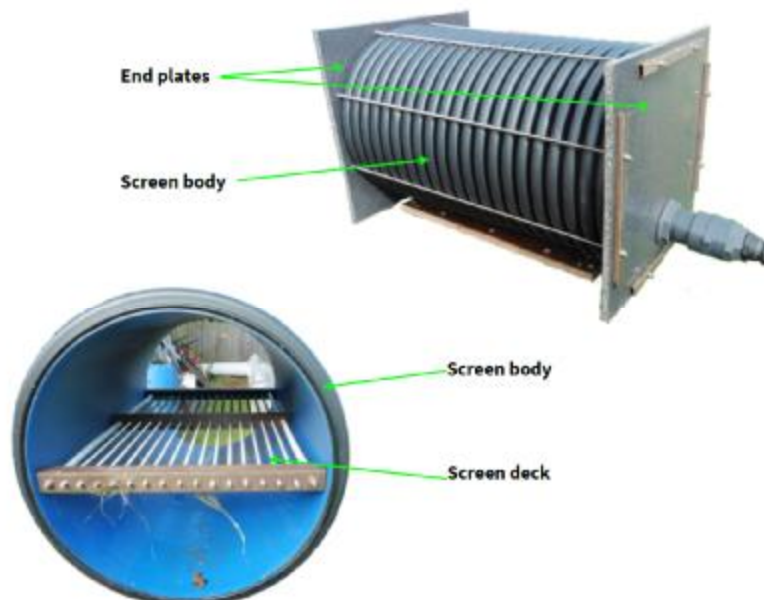

Centralized Treatment: Scaled Up Testing of Chemical Additives for Sludge Treatment

Background

To avoid disposal of untreated faecal matter into the environment, treatment options that can sanitize (kill pathogens) and stabilize faecal matter (reduce vector attraction), need to be employed in the immediate phase of emergencies. Several chemical and biological processes have been tested in the field for their efficacy in an emergency set-up. Multiple studies carried out to establish efficacy of treatments in the context of an emergency have concluded that treatment of faecal sludge using urea, lime and lactic acid fermentation can sanitize faecal sludge safely in between 3 and 15 days if certain conditions are provided⁸. However, these studies did not investigate the efficiency of faecal sludge treatment at large scale.

Manufacturers of additives claim that their products increase the rate of decomposition. Earlier research on the use of additives to stabilize faecal matter gave variable results; some state that biological additives work⁹ while others claim that they do not¹⁰. The observed differences may be attributed to the difference in stabilizers, method of application and management issues (number of users, almost full pits, ownership of facility and whether the pit was or was not in use during the experimental period).

In the first phase of the ESP, WASTE and its sanitation partners carried out research to determine whether commercially available additives can stabilize and sanitize faecal sludge. The initial finding in ESP Phase 1 indicated that chemical additives were efficient in terms of pathogen reduction and organic matter decomposition.

Work carried out in Phase 2

As the Phase 1 testing was done at lab and small scale, the present research aimed to determine the treatment effectiveness of lime, caustic soda and urea in 2000 litre storage tank. The additives tested were:

No	Additive name	Product description	Category
1	Soda	Lab grade Sodium Carbonate	Chemical
2	Lime	Alkaline or Lime stabilization is a simple process which reduces odour, vector attraction and pathogen levels in wastewater and wastewater treatment sludges (also known as biosolids) ¹¹ . The process involves the application of an alkaline substance such as calcium hydroxide (Ca(OH) ₂) to increase the pH and create a highly alkaline environment which is hostile to biological activity ¹² .	Chemical
3	Urea	Urea Treatment is based on the sanitizing effect of uncharged ammonia (NH ₃) which has been demonstrated to be a harmless chemical substance capable to efficiently inactivating bacteria ¹³ .	Chemical

⁸ de Pooter, 2014; González Pérez, 2014; Malambo, 2014; Nobela, 2014

⁹ Jere et al., 1998; Taljaard et al., 2003

¹⁰ Bakare, 2011; Buckley et al., 2008; Foxon et al., 2008

¹¹ Williford, Chen, Shamma, & Wang, 2007

¹² Schwing BioSet, 2009

¹³ Vinneras, Nordin, Niwagaba, & Nyberg, 2008

The test parameters, reagents, apparatus and analytical method used for the analysis were:

Parameter	Reagents/ Materials/Glassware	Apparatus	Method
Total COD	Digestion solution (Water, K ₂ Cr ₂ O ₇ , conc. H ₂ SO ₄ , H ₂ SO ₄ /Ag ₂ SO ₄) Stock solution (Potassium hydrogen phthalate dissolved in water)	Digestion vessels Oven to operate at 150±2°C Spectrophotometer to operate at 600 nm	Standard method SM 5220D Closed reflux method
Total solids and Volatile solids		Oven, 105°C Analytical balance (10mg accuracy) Evaporating dish Muffle furnace	Standard method SM 5540G Gravimetric method
pH		WTW pH 340i field meter	
Temperature		Mercury Thermometer	
E. coli	Chromocult coliform agar(Merck Millipore) Distilled water Cotton wool Aluminium foil Peptone Sodium chloride	Autoclave Incubator, (37±2°C) Water bath controlled thermostatically at, 100°C pH meter Burner flame Petri dishes (90mm) Glass spreader	ISO 9308-1 Surface plate method
Enterococci	m Enterococcus agar (Difco) Distilled water Cotton wool Aluminium foil Peptone Sodium chloride	Autoclave Incubator, (35±2°C) pH meter Burner flame	ISO 9308-1 Surface plate method

Two different experimental units were set-up. The first was done at WASTE Advisers office in Blantyre Malawi, where three storage tanks of 2000 litre capacity were loaded with faecal sludge collected from pit latrines and three types of additives were applied under two different conditions (mixed and non-mixed). Mixing was conducted using a circulation pump. The second type of set-up

was combined with the testing of the earth auger and Loowatt toilets and is described in that section of the report.



2000 litre storage tanks, filled up with faecal sludge

Results

The characteristics of faecal sludge were tested at laboratory at WASTE office and at the Polytechnic University of Malawi in Blantyre. The characterization of faecal sludge used in the laboratory and field experiments respectively was:

Parameter	Units	
Total COD	mg O ₂ /L	2,960 to 11,253
Total solids	%	0.64 to 12.20
pH		7.27 to 7.9
Temperature	°C	18.5 to 25.1
E. Coli	CFU/100mL	1.93E+04 to 4.25E+05

The concentrations of E. Coli in treated black water was enumerated and compared to the WHO guideline value for restricted agriculture which is <1000 cfu faecal coliform/100ml (100g) of sample. When the additives were applied without mixing the concentrations of E. Coli increased, consequently no sanitization process happened.

When the additives were applied mixing the faecal sludge with them, a sanitization process took place. After one day of lime and urea application the faecal sludge was sanitized as no pathogens could have been identified. For caustic soda, three days after treatment and with daily mixing the faecal sludge was sanitized (concentrations below 1000 cfu faecal coliform/100ml (100g) of sample)

The parameter evaluated on this research to establish the stability of treated sludge was VS/TS ratio. A stable sludge has VS/TS less than 60% and has achieved a volatile solids reduction $\geq 38\%$. VS/TS of stable sludge was obtained using the equation below:

$$VS_{stable\ sludge} \leq 0.62 VS_{influent} \text{ (Achieve } > 38\% \text{ Volatile solids reduction)}$$

On the trial done without mixing the additives with faecal sludge, there was not significant reduction on the concentration of organic matter.

On the trial with a mixing condition, only the tank mixed with urea reached the volatile solids reduction level required to determine as stable sludge. Regarding the tanks mixed with lime and caustic soda, although there was a significant reduction of volatile solids, they could not be identified as stable sludge.

Based on this trial, we can conclude that, when using chemical additives such as lime, soda and urea, rapid stabilization and sanitization of faecal sludge is most likely to be achieved when they are mixed. Because of the type of sludge used on the test the mixing process, which used a membrane pump, was difficult and required multiple mixing sessions. Significant reduction in concentrations of *E. coli* was observed in faecal sludge treated with additives of chemical origin. Lime also reduced the pathogen concentration faster than caustic soda. While lime and urea brought pathogen levels down to acceptable limits in one day, caustic soda demanded three days to reach the recommended level.

Centralized Treatment – Development of the IFRC Aerobic Faecal Waste Treatment Unit for Deployment to Acute Emergencies

Background

While decentralized, on site treatment has many advantages, centralized treatment can offer greater efficiency and easier process control oversight, particularly at scale. However, the WASH sector has struggled to provide a solution for centralized treatment of faecal sludge or wastewater in the acute stage of emergencies.

In the first phase of the ESP, the IFRC explored a number of options for centralized faecal sludge and wastewater treatment. While some technologies failed in early trials, others demonstrated potential to improve at least the basic treatment of human waste. None, however, were deemed suitable for stockpiling or use in prepositioned equipment packages that would enable rapid response to FSM needs in acute emergencies. Many view faecal waste treatment as entirely context specific. While noting that no technology is universal, the IFRC believes that equipment packages similar to the ones we stock and deploy for water treatment and basic sanitation are feasible for faecal sludge and wastewater treatment, and at a comparable price point. The IFRC thought that the most viable solution was a system of combined treatment processes to enable large scale treatment of a variety of faecal waste in a range of contexts and, with the groundwork laid out in Phase 1, set out to create such a package.



Work carried out in Phase 2



After a period of review and refinement of previously tested equipment, the IFRC held a 3-day workshop in July of 2017. The workshop brought together 19 engineers and technicians from inside and outside the Red Cross Movement. Equipment was assembled and assessed for its feasibility to deliver results in field conditions. A number of designs were developed and debated. While several, including lagoons, were practical enough for use

in emergencies, one design was deemed most in line with the desire for a rapidly deployable package for a wide range of contexts.

While work began to shape the design and procure the different components, less than a month after the workshop the IFRC joined a large number of humanitarian aid agencies in responding the needs of hundreds of thousands of people near Cox's Bazaar, Bangladesh. While the initial plan was to trial the unit in a non-emergency setting, the humanitarian needs and the relative ease of deploying IFRC and Red Cross Red Crescent WASH personnel led to the reluctant and heavily criticized decision to conduct the trial in the Population Movement Operation. While this led to customs and weather delays, the IFRC is confident it was the right decision. Cox's Bazaar has become a hub for FSM innovation and learning. We have been able to learn from others and demonstrate the effectiveness of our approach to a wider audience.

The unit uses existing and novel technology for primarily aerobic treatment of faecal sludge and wastewater. The plant currently operating in Bangladesh consists of two T45 steel tanks (one for aeration and one for settling), pumps, aerator, mixer, glass bead filter, inline chlorinator for supernatant and anaerobic digester for treatment of accumulated sludge. This unit is currently estimated to serve a population of around 5'000 people with possibility to scale up.



Surface mixing Unit



Surface aerator

Although equipment was in place by April of 2018, the decision was taken to postpone the trial until after the monsoon rains and begin work in September 2018. Unforeseen challenges, particularly with the electrical wiring and the tank panels, have caused significant delays while also providing valuable learning experiences. Not only were these issues resolved, they are unlikely to affect future deployments. The aerator and mixer can be ordered with wiring complete and the tanks are easily reinforced with sandbags to withstand the repetitive stress of the mixing action.

The plant began to take on human waste in November of 2018. The most serious setback occurred in January 2019. Due to an incorrect speed setting on the mixer, large amounts of foam began to build up on the surface of the reactor tank. In the 2-week absence of the process engineer, the operating crew began to turn off the aerator and mixer for extended stretches and the unit went anaerobic in a few days. Once again, this provided extremely useful learning for the future use of the plant. The foam issue was resolved with surface skimming initially and then adjustment to the mixer. The operating protocol was modified to ensure 24/7 operation to maintain aerobic conditions. In the event that the unit once again became anaerobic, the operating manual contains a troubleshooting guide to remove the anaerobic material and restore aerobic conditions.

Results

As this was a pilot, we were unsure whether the process would work at all. We therefore sent less equipment for aeration and mixing than ideal for the size of tanks installed. The dissolved oxygen levels in the unit are within the acceptable range, but the loading rate of wastewater is lower than planned and lower than the tanks could handle if better aerated. Notably, the unit does not produce strong odours or attract insects. Power consumption is low, resulting in low operating costs. The recent review of FSM in Bangladesh carried out by Oxfam and Arup¹⁴ scored the system high on effectiveness and efficiency. We are confident that results would improve significantly with small upgrades to the system

After the January anaerobic incident was addressed, the unit began to function more consistently. As of June 2019, the unit is still running, with steady improvement in performance. COD levels were nearing the Bangladesh standard of 200 mg/L and the unit was achieving near total removal of intestinal parasite eggs. It is hoped that the installation of an anaerobic baffled reactor for pre-treatment will reduce the solids entering the system and increase loading rate and effluent quality. A planned conversion to solar power for energy efficiency has faced internal procurement delays but should be finalized soon.

In addition to the treatment unit, the IFRC also deployed the newly developed Faecal Sludge Field Laboratory (FSFL). Developed with HIF support by a consortium led by the Austrian Red Cross, the FSFL allows the humanitarian sector to determine the nature of human waste, plan appropriate response, and monitor the performance of waste treatment methods in an emergency field setting. The FSFL began analysing samples from the aerobic plant and a British Red Cross run lime treatment facility in January 2019. Samples from other organizations are also tested on a small-scale basis. The FSFL has provided critical data on the effectiveness of the IFRC plant. The IFRC strongly advocates that all organizations engaged in FSM operate a similar laboratory.

Next Steps

The pilot in Bangladesh will continue to run as long as possible, though the field operation may convert the site to another treatment solution. The IFRC is currently seeking support to test a larger unit in a different location. The Fact Sheet for the IFRC Aerobic Waste Treatment Unit, attached to this report and available at the ESP website, contains the specification for the upgraded unit. Although it is larger, it can be packed in a 40 ft container. We are also beginning to develop the necessary pool of human resources needed to operate the treatment plant and laboratory.

While we acknowledge that no system can be suitable for every context, we strongly believe that the unit can function in a wide array of geographical and sociocultural contexts. Aerobic treatment is in use across the globe. Outside of cold climates, its primary limitation is the sustainability issues (cost, spare parts, technical capacity for operation and maintenance) that affect infrastructure in all low-income settings. However, in an acute emergency these considerations can be mitigated more easily.

¹⁴ Available for download at <https://arup.sharefile.com/share/view/sb5936ce71df4e85b>